

INDUSTRIAL CRANES
NUCLEAR CRANES
PORT CRANES
HEAVY-DUTY LIFT TRUCKS
SERVICE
MACHINE TOOL SERVICE

REACH STACKERS

KONECRANES®
Lifting Businesses™

 **FORKLIFTCENTER**

10–80 tons
REACH STACKERS
WITH HEART







Remarkable versatility FROM CONTAINERS TO INDUSTRIAL CARGO

We have a long history of working with container ports and intermodal terminals that are expert buyers and operators of reach stackers. Our container handling customers demand a lot of us, and we have a long track record of meeting their requirements year after year.

Larger reach stackers are needed for railroad stacking. To load and unload on more than one track you need a flexible reach stacker with a large lifting capacity and an extended set of functions. You will find a reach stacker in our range that will meet the specific requirements of your terminal.

Industrial workhorses

We also work with many industrial companies that need customized reach stackers for their specific industry. Our reach stackers are remarkably adaptable to industrial cargo handling. We provide special spreaders incorporating steel grabs, lifting magnets, vacuum grippers, and coil C-hooks among other attachments. What kind of material do you need to lift and move? Contact us. You'll probably find we have plenty of experience in your industry and can provide the ideal reach stacker.

Applications

- Container ports and terminals
- Railroads and intermodal
- Trimodal river handling
- Transport, shipping, and logistics
- Steel and aluminum
- Automotive
- Oil and gas
- Wind power
- Nuclear power
- Waste-to-energy



**Made with heart
in every detail**

SMARTER WHERE IT MATTERS

Konecranes has been manufacturing, selling, and supporting heavy-duty lift trucks for some 60 years. Buy a reach stacker from us today and you will get the latest technology, the lowest Total Cost of Ownership, and a reach stacker made with heart.

We claim the lowest Total Cost of Ownership with our reach stackers, understood as an equation running over a time period of years as shown below. When you're shopping around the suppliers and comparing prices, our truck will probably not be the cheapest. But it will provide the best value over time.

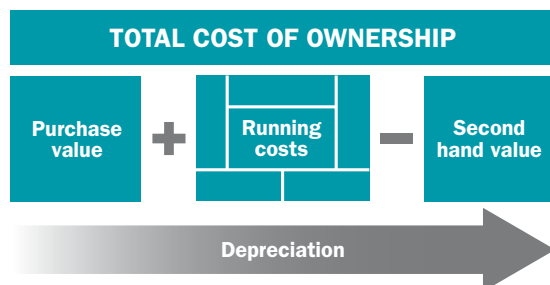

Close to you

We sell our lift trucks around the world in two ways: directly via our own sales and service organizations, and indirectly via distributors. In both cases, our lift trucks are fully supported with quickly delivered spare parts and personalized service. Konecranes has the widest service reach of any company in the lifting business. And our distributors are some of the most respected in the business.

Service made easy

To reduce lifetime running and maintenance costs, we have extended the service interval of the engine by 500 hours, the gearbox by 1000 hours, and the hydraulics by 4000 hours.

Our HLL ultra-fine filter system extends the hydraulic oil change interval from 4000 up to 12000 hours. In practice, you will use up to 80% less hydraulic oil than with a conventional hydraulic system.

GENUINE KONECRANES PARTS

Genuine Konecranes parts are the best protection for your investment. They pay off in truck performance and uptime.

PARTS ONLINE

> Easy to find, easy to buy

REAL-TIME SHIPMENT INFORMATION

> You know where your parts are

FAST DELIVERY

> Parts in stock are in your hands within 1–3 days

PROTECTION BOX

> All the filters you need, in one package





1 Modern and durable lifting spreaders

Top-lift for 20/40/53 ft containers, 300 degrees rotation, 1600 mm total sideshift, 4 lift eyes for sling cargo. MPS mechanical (± 2 deg) or HPS hydraulic pile slope (± 6 deg). The combi spreader can also lift trailers and swap bodies with 4 folding lift legs.

2 Smart load-sensing hydraulics

They sense the load and adapt the lifting power to the weight of the load. The truck provides maximum power only when really needed, so it consumes less fuel while reducing emissions and noise.

3 Powerful engine

Certified low-emission engine provides extra high torque at low revs for reduced fuel consumption and low noise levels. We offer a variety of engines for EU stage 4 and EPA Tier 4f.

4 OPTIMA – probably the best cabin on the market

Every detail has been carefully designed for comfort and safety. Controls, displays, ventilation, and seating work to boost driver productivity. Excellent visibility in all directions.

5 Electronic Machine Control, EMC Master

Full monitoring of all the vital components and functions on a 7" touch screen. Programmable settings. CanBus technology increases engine and transmission reliability as well as hydraulics and joystick control.

6 Heavy-duty box-type chassis

The strongest on the market. The foundation of long-lasting high performance.

7 Maintenance-free brakes

Brakes with continuous oil cooling provide full braking power in every situation.

8 Excellent stability

Wide, strong drive axle and long wheelbase. The two keys to excellent stability for safe lifting of heavy loads.

Intermodal operations, Helsingborg, Sweden



Satisfied customers
around the world
**OUT IN
THE FIELD**

Worldwide, Konecranes reach stackers are hard at work across an amazing range of container handling and industrial applications.

Multi-purpose operations, Germany



Laden container handling, Norway



Steel slab handling, Finland



Empty container handling, Germany



La Spezia, Italy



Intermodal operations, UK



Laden container handling, China



Oil and gas pipeline handling, Norway



Intermodal operations, Helsingborg, Sweden



OPTIMA ENHANCED SPACIOUSNESS AND VISIBILITY

Customized for your container handling needs.

When you step inside OPTIMA cabin, you find outstanding spaciousness and superior visibility. That makes operating the lift truck safe and efficient, along with valuable extra equipment.

The remarkable visibility is made possible by very large, lowered windows with no corner posts, thin but very strong roof crossmember, and curved panels. Sightlines to key working areas are clear both in the front, to the sides, and to the rear.

New EMC Master with MD4 7" touch screen enables a more spacious cabin with its integrated solutions. There is also more space for operating the foot pedals.

The positioning of the instrumentation improves operating ergonomics. Instrumentation has been moved from the driver's left side to his right, above his seat, where it is conveniently accessible.

OPTIMA is customizable for your exact operational needs. You can select mini-wheel steering, lever steering, the driver's seat, and precisely the instrumentation that you need. A hydraulic sliding cabin (stroke 2900 mm), a vertically movable cabin RHS (stroke 2850 mm), and EMC remote control are also available.

1 Remarkable visibility

You know great visibility when you see it. Sitting down in OPTIMA shows you what superior visibility means.

2 Electronic Machine Control,

EMC Master

Full monitoring of all the vital components and functions on a MD4 7" touch screen. Programmable settings. CanBus technology increases engine and transmission reliability as well as hydraulics and joystick control.

3 Left armrest mini-steering options

Optional, ergonomic steering solutions that improve productivity.

4 Ergonomic instrumentation

Whatever extra equipment you need, we can install it as part of an ergonomic instrumentation layout. OPTIMA is truly spacious.

5 Comfort

An excellent seat with compressor suspension, powerful cabin heating and ventilation, air conditioning – the driver is provided with every possible comfort.

6 Joystick control

Available with electronic joystick with auto accelerator/power control.



Lever steering with return



Mini-wheel steering



Lever steering without return



Remote control unit for rail and barge handling

A world of options

BOOSTING SAFETY AND EFFICIENCY

Konecranes invests significantly in reach stacker R&D to be the first to offer new technologies that improve performance and safety. We also ensure that our reach stackers are fully compliant with emissions regulations, anticipating their evolution as a normal part of our product development process.

Emissions-compliant diesel engines

We offer a wide range of powerful Volvo and Scania engines certified according to EU stage 4 and US EPA Tier 4f.

EMC Master

Our Electronic Machine Control system, EMC Master, provides the following functions as standard:

- Electronic overload & safety system
- Full truck monitoring
- ECO-Drive and fuel management
- Productivity counter management
- Driver log-in (20 drivers)
- Data logging of alarms and errors
- Transport mode (boom/spreader load optimizer)
- Auto accelerator / power control

The following functions are optional:

- Vertical auto-lift function
- Horizontal auto-lift function
- Remote control unit (railroad/barge loading)
- Electronic weight scale
- Mini-wheel steering
- Lever steering
- Auto engine shut-down
- Auto parking brake
- Drive speed limitation (unloaded/loaded)
- Remote Access Service via GPRS/(3G)
- TRUCONNECT Remote Services

TRUCONNECT® Remote Monitoring and Reporting

TRUCONNECT Remote Monitoring and Reporting enables you to track the real usage of your lift trucks through a remote connection. It provides you with an online view and periodic PDF reports that illustrate the actual use of your lift trucks, making it a great tool for scheduling your lift truck fleet's maintenance actions and consequently improving the fleet's uptime.

The reports include:

- Safety alerts
- Machine status
- Average fuel consumption
- Average fuel consumption per lifted load
- Total fuel consumption
- Traveling distance
- Average traveling speed
- Load spectrum
- Total load lifted
- Tire pressure monitoring
- Collision sensors
- Cleanliness of hydraulic oil

Tire pressure system

Under-inflated tires can increase fuel consumption by as much as 15% while impairing stability and drivability. Our tire pressure system makes it easy to keep your lift truck tires properly inflated. It's installed in minutes. If you combine it with the drive speed limitation provided by EMC Master you can extend the life of your tires even further.

Fire alarm and suppression system

We offer an effective fire alarm and suppression system that can be activated either manually or automatically. When the reach stacker is in use, the system discharges in one of three ways: manually from inside the cabin; manually from outside via a mudguard trigger; automatically, triggered by sensors in the engine compartment. When the reach stacker is not in use, i.e. when the master power switch is turned off, the system discharges automatically when the fire alarm goes off.

Other safety options

- Parking Distance Control (PDC) with sensors for driving in reverse.
- Breath Analyzer: an alcohol test unit which requires the driver to take a breath test before starting the reach stacker.
- Camera Supervision System: can be mounted as a reversing camera on the rear of the reach stacker or as a forward camera mounted on the spreader or chassis.

1



2

REMOTE V



Portal

Kon
Remote



WORKFLOW



Konecranes
Data Center



Modem

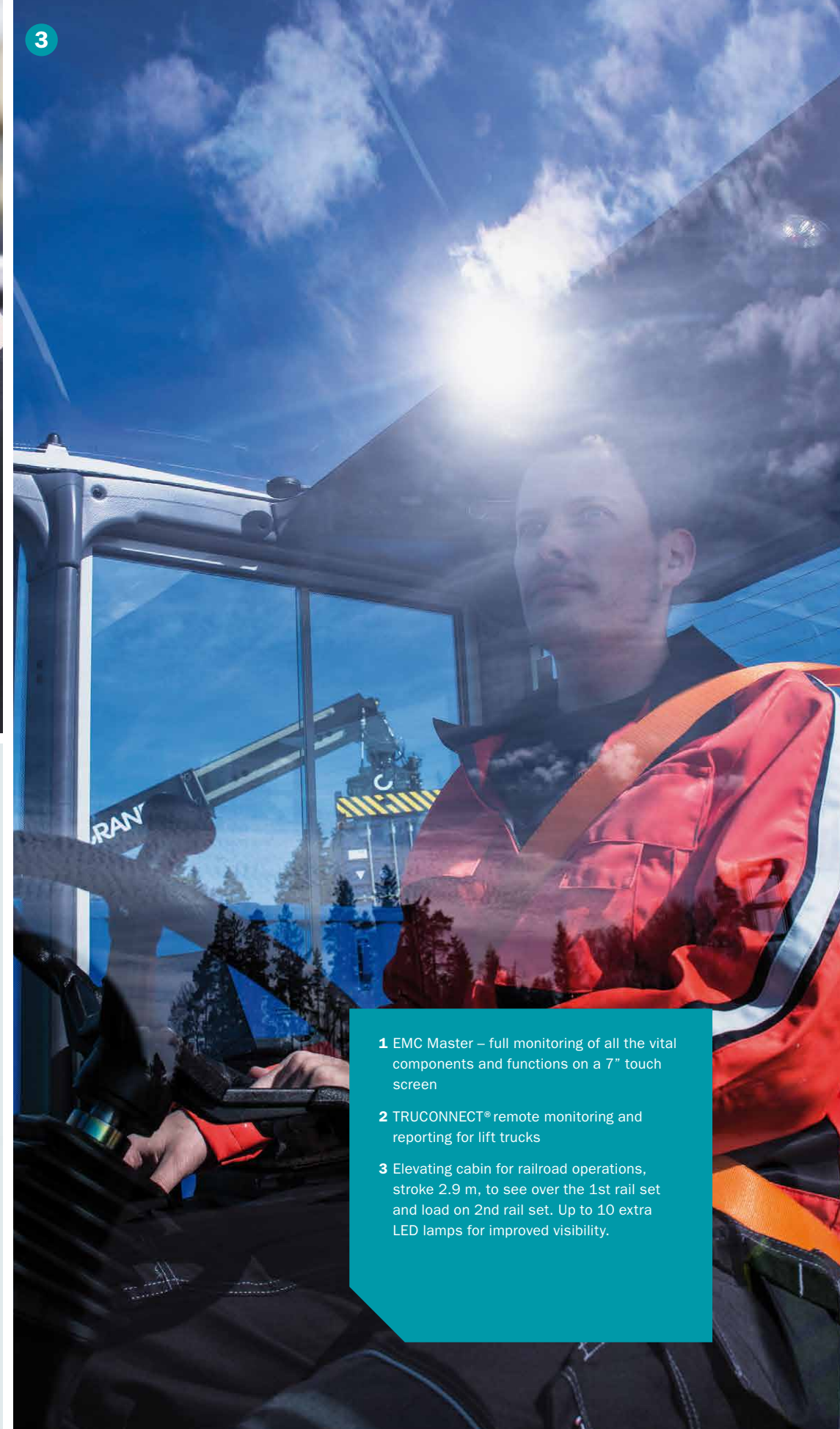

- 1** EMC Master – full monitoring of all the vital components and functions on a 7" touch screen
- 2** TRUCONNECT® remote monitoring and reporting for lift trucks
- 3** Elevating cabin for railroad operations, stroke 2.9 m, to see over the 1st rail set and load on 2nd rail set. Up to 10 extra LED lamps for improved visibility.

What do you need to lift? **WE HAVE THE ATTACHMENT**

You'll find your lifting solution in our complete range of attachments for reach stackers.



Container handling



ELME 517-MPS

Telescopic spreader for empty ISO containers with capacity up to 10 tons. Strong and well-proven single beam spreader design, floating twistlock (± 10 mm) with hydraulic operation and mechanical safety locking. Hydraulic extension with 2 cylinders (20–40 ft), large sideshift (± 800 mm) with 1 hydraulic cylinder and full rotation ($-105/+195$ deg) with 1 hydraulic motor (turning) and 1 brake (holding). Spreader side tilt ± 2 deg (MPS = mechanical pile slope). The spreader frame and the end beams are of strong heavy-duty design. Weight = appr. 4.8 tons.

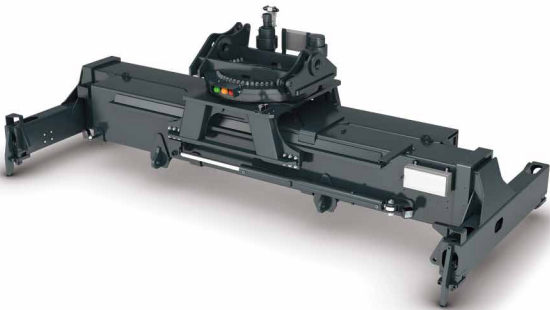

ELME 817-MPS

Telescopic spreader for laden ISO containers with capacity up to 45 tons. Strong and well-proven parallel double beam spreader design, floating twistlock (± 10 mm) with hydraulic operation and mechanical safety locking. Hydraulic extension with 2 cylinders (20–40 ft), big sideshift (± 800 mm) with 2 hydraulic cylinders and full rotation ($-105/+195$ deg) with 1 hydraulic motor (turning) and 2 brakes (holding). Spreader side tilt with stroke of ± 2 deg (MPS = mechanical pile slope) and 4 lift eyes included for slings (45 tons). ELME 817-HPS with a stroke of ± 6 deg (HPS = hydraulic pile slope with 4 cylinders). The spreader frame and the end beams are of strong heavy-duty design. Weight 817-MPS/HPS = appr. 9.3/10.3 tons.



ELME 817-MPS/OFL (folding)

With overheight folding legs for open-top containers and flat racks (extra high cargo). The foldable extension legs are 1600 or 2100 mm long and activated by 4 cylinders. Weight appr. 10.3–11.3 tons.



ELME 817-MPS/OFL in action

Above, legs shown in unfolded position with an open-top container with high cargo. Flat racks often have overheight cargo that must be lifted like this.

Also available

- Pipe and tube handling attachment
- Clamp for steel handling

Several others available upon request



Intermodal handling



Industrial handling



ELME 857-HPS (folding)

Telescopic intermodal spreader (combi/piggyback) for laden ISO containers, swap bodies, and trailer handling with capacity up to 45 tons (in twistlocks / in lift legs). Extension 20/B7/30/40 ft is included. The lift legs “fold in” and “fold out” in a sequence with sensors in each lift leg / lift shoe. Leg length = 3600 mm and leg opening = 1700–3200 mm. The package of spreader frame and legs is of strong heavy-duty design. All container functions as for ELME 817-MPS/OFL. Weight appr. 13.6 tons.



ELME industrial tool carrier system

For connecting tools (connection points = 2500 x 760 mm). Strong and well-proven single beam spreader design, floating twistlock (± 10 mm) with hydraulic operation and mechanical safety locking. Large sideshift (TC-50 = ± 500 mm / TC-65 = ± 300 mm) with 1 hydraulic cylinder and full rotation ($-105/+195$ deg) with 1 hydraulic motor (turning) and 2 brakes (holding). Spreader side tilt ± 2 deg (MPS) or ± 6 deg (HPS). The spreader frame and the end beams are of strong heavy-duty design. Weight TC-50-MPS/TC-65-MPS = appr. 5.0–7.5 tons.



ELME 857-HPS in action

Legs shown in unfolded position with a trailer being lifted.



Hydraulic steel slab grab unit

Hydraulic steel slab grab unit with pairs of hydraulic lifting jaws. The grab can lift 1–4 slabs if the height adjustment function is included. Various slab width combinations are available, width min–max 700–1800/900–2000/1500–2600 mm. Capacities up to 50 tons (in grab unit). Grab weight = appr. 9.0–12.0 tons.

EQUIPMENT

For all Konecranes reach stackers

STANDARD EQUIPMENT

TRUCK BODY

Box-type chassis

- Strong box profile and crossmembers
- Thick steel plate reinforcement, both front and rear
- Safe, ergonomic access steps and hand rails LHS+RHS
- Strong lift cylinder and boom fixations in chassis
- Lifting eyes, front and rear in the chassis/boom

Standard colors

- Chassis, tanks, mudguards & rear: seagreen NCS S2555 B30G
- Mast, carriage, spreader & axles: black RAL 7021
- Cabin & engine hood: light grey RAL 70335

Steel mudguards

STEERING AXLE

- Smooth power steering with double-acting cylinder
- Wide steering angles providing small turning radius

DRIVE AXLE

Kessler D81/102/106/111

- Wide axle with 2-stage hub reduction and differential
- Oil-cooled, maintenance-free wet disc brakes

DIESEL ENGINE

See technical info charts

- Certified for EU stage 4 / EPA Tier 4f
- Low-emission
- Clean, powerful, fuel-efficient with CanBus controls

Engine air filter, 2-stage type

TRANSMISSION

SMV 108–2518; ZF 4WG-191 (4+3 gears)

SMV 4123–4545; DANA TE-27 (4+4 gears)

- Fully automatic, softshift
- Torque converter, smooth powershift, declutch, reverse protection, CanBus controls

COOLING SYSTEM

Tropical, multi-radiator

- Radiators for engine water, air for intercooler, oil for transmission
- Oil cooling / flushing for brakes

HYDRAULIC SYSTEM

Load-sensing, power-on-demand

- Smooth, accurate, high-speed lifting and lowering
- Variable piston pumps with intelligent control
- Leak-free ORFS couplings (O-ring) for entire truck
- Large dual tanks for hydraulics and brakes with return filters (12 microns)

ELECTRICAL SYSTEM 24 V

Alternator standard size 100–110 Ah

LIGHTS

Full road lighting LED: blinkers, brake lights, tail lights, position lights

- 2 x LED front lights on mudguard
- 2 x LED reverse lights on counter weight
- 4 x LED work lights in lift boom
- 2 x LED work lights on spreader

OPTIONAL EQUIPMENT

TRUCK BODY

- Fire extinguisher on truck body or inside cabin
- Fire fighting system for driveline compartment (semi-automatic)
- Galvanized storage boxes with lid (on bottom step)
- Central greasing unit for truck and spreaders
- Custom colour painting, stickers & customer logos

Different mud flap models, front and rear

STEERING AXLE

- Wheel nut protection and steering cylinder spacers

DRIVE AXLE

DIESEL ENGINE

SMV 108–2518: Volvo (185 kW / 1160 Nm)

SMV 4123–4545: Volvo, Scania (257–294 kW / 1785–2157 Nm)

- Certified for EU stage 4 / EPA Tier 4f
- Low-emission
- Clean, powerful, fuel-efficient with CanBus controls

Engine air filter Turbo II, 2-stage cyclone type

TRANSMISSION

SMV 4123–4545; DANA TE-32 (4+4 gears) and ZF 4WG-261 (4+3 gears)

- Fully automatic, softshift
- Torque converter, smooth powershift, declutch, reverse protection, CanBus controls

COOLING SYSTEM

- Extra radiator / cooling circuit for hydraulic system

HYDRAULIC SYSTEM

- High pressure filters (12 um)
- HLL hydraulic longlife filters (3 um)
- Hydraulic oil cooling circuit for working hydraulics

ELECTRICAL SYSTEM 24 V

- Reverse alarm (beeping)
- NearGuard RFID warning system (receiver and transmitters)
- NATO starting aid contact
- Built-in battery charger
- Pre-heater for engine, transmission, hydraulics and cabin
- Power connections 400V/3-phase for multiple preheaters

LIGHTS

- Extra work lights: Xenon or LED
- LED warning beacons
- LED strobe warning flash lights: front, rear, or other position

STANDARD EQUIPMENT

CABIN
Two doors
L x W x H = 1605 x 1480 x 1620 mm
Sliding cabin
TC models: manual sliding, stroke 1800 mm
CC models: hydraulic sliding, stroke 2900 mm
Spacious, comfortable, excellent ergonomics
Excellent visibility: no front corner posts
Powerful heating and cooling unit
Electrical connection 24V (1 x in cab roof RHS)
3 x windshield wipers / washers
Adjustable seat, seat belt, steering wheel
Joystick (electronic servo / auto throttle)

MACHINE CONTROL
EMC Master intelligent machine control, display: MD4, size 7"
Monitoring of engine, transmission, hydraulic system, service, electronic joystick, spreader, counters, and info
EMC Safety, overload, and load management system
EMC 106: Monitoring (diagnostics / parameters / settings)
EMC 114: Electronic servo joystick (auto-throttle)
EMC 123: ECO-Drive (fuel consumption, saving, settings)
EMC 124: Driver log-in (up to 20 drivers)
EMC 125: DATA-Log (storage of alarms and errors)
EMC 129: Productivity Hour Counter
EMC 130: Transport mode (boom / spreader position)

BOOM
2-stage box-type lift boom
Strong box profile and cross-members
Thick steel plate reinforcement, both front and rear

SPREADERS
SMV 108: ELME 517 (10 t)
Stops 20–40 ft, 4 pendular twistlocks, rotation 300 deg
Mechanical Pile Slope ± 2 deg, sideshift ± 800 mm
SMV 4127–4545 TC: ELME 817 (45 t)
Stops 20–40 ft, 4 pendular twistlocks, rotation 300 deg, 4 lifting eyes
Mechanical Pile Slope ± 2 deg, sideshift ± 800 mm
SMV 4123–4545 CC: ELME 857 (45 t)
Stops 20/30/40 ft, 4 pendular twistlocks, 4 lifting eyes,
Hydraulic Pile Slope ± 6 deg, sideshift ± 800 mm
PDC Power Damp Control + tilt lock, 4 lifting legs

INDUSTRIAL HANDLING
Models SMV 108–2518–4127–4545 TC

SERVICE AND PARTS
Standard warranty 12 months / 2000 hours

OPTIONAL EQUIPMENT

CABIN
TC models: hydraulic sliding, stroke 2900 mm
TC/CC models: vertical moveable cabin RHS, stroke 2850 mm
Extra mirrors inside cabin
Reverse, front, and spreader cameras with 6.7" display (MOTEC)
Air conditioning or climate control unit (stepless fan speed)
Extra electric cabin heater 220V (DEFA)
Extra diesel-powered cabin heater (Webasto)
Extra electrical connections 24V (cab roof or front panel RHS)
Extra electrical connections 12V (cab roof or front panel RHS)
Interval wiper speed switches: front, roof, and rear windows
Pneumatic compressor horn
Various seats BEGE, ISRI, Grammer
Additional seat dampening: single or double
Two-point or three-point seat belt
Seat heating
Extra trainer's seat, fully-foldable LHS
Tire pressure monitor: cabin display, 6 tire sensors
Sun blinds: front, roof or rear windows, fixed or adjustable
Alcohol lock / start-up prohibitor (Draeger)
Reverse alarm (beeping)
Universal mounting system for RHS for A4/A5 writing pad, keyboard, computer, monitor, com radio, and reading lamp
CD player / radio / MP3 player with dual loudspeakers

MACHINE CONTROL
EMC 102: Lever steering (with spring return to zero)
EMC 103: Lever steering (no spring return to zero)
EMC 104: Mini-wheel steering (speed progressive steering function)
EMC 107: Electronic weight scale (resolution 0.1 ton)
EMC 112: Auto engine shut-down timer
EMC 122: Drive speed settings (on/off, programmable)
EMC 126: GSM remote access
EMC 131: Vertical lift
EMC 132: Vertical lift / horizontal outreach
EMC 133: Remote control units for rail and barge handling
NearGuard RFID warning system (receiver and transmitters)

BOOM
Long-nose boom to reach ground level (extended 1000 mm)
Long-nose boom to reach ground level (extended 1500 mm)
Distance piece (extended 1500 mm) between nose and rotator (for barge)
Distance piece (extended 2000 mm) between nose and rotator (for barge)

SPREADERS
Extra stops at 24/30/35 ft
Hydraulic Pile Slope ± 6 deg
Extra stops at 24/30/35 ft
Hydraulic Pile Slope ± 6 deg
Power Damp Control (PDC) ± 5 deg
Over-height folding legs 1600 and 2100 mm
Separate ELME 952/953 Bottom Trailer Lift (2/4 fold legs)
Extra lifting eyes 2 x in centre or 4 x at 2500 mm distance

Extra stops at 24/30/35 ft

INDUSTRIAL HANDLING
ELME 7000 and 7010 tool carriers (50 and 65 tons)
Steel slab grab, coil hook for coils, magnet for steel (mounted on tool carrier)
Lifting hook on boom nose, free pivot, free rotation, no power (30–80 tons)

SERVICE AND PARTS
Extended warranty on truck and driveline (18–36 months / 3000–6000 hours)
Spare tires, rims, complete wheels: various brands
Spare part kits: basic, extended, special
Complete filter kits: 2000 hours up to 8000 hours

PREMIUM PERFORMANCE IS WITHIN YOUR REACH

Reach stackers for container handling, 10 to 45 tons

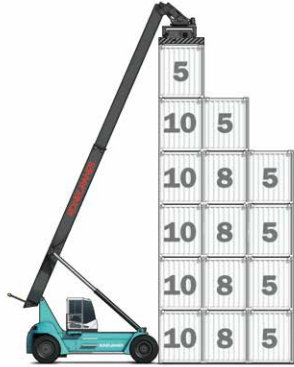

MODEL NAME	CAPACITY	WHEELBASE
SMV 108 TC6	10-8-5 tons	5000 mm



MODEL NAME	CAPACITY	WHEELBASE
SMV 2115 TC3	21-15-5 tons	5500 mm
SMV 2518 TC3	25-18-8 tons	5500 mm

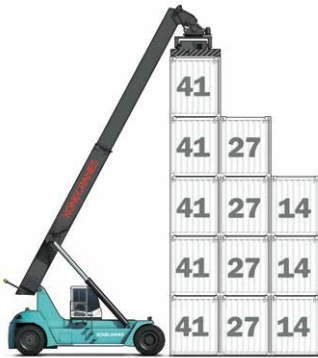

MODEL NAME	CAPACITY	WHEELBASE
SMV 4127 TC5 (TC6)*	41-27-14 tons	6400 mm
SMV 4527 TC5 (TC6)*	45-27-14 tons	6400 mm
SMV 4531 TC5 (TC6)*	45-31-16 tons	6400 mm

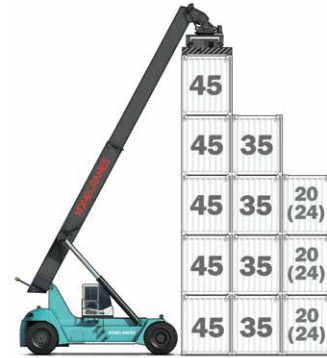

MODEL NAME	CAPACITY	WHEELBASE
SMV 4535 TC5 (TC6)*	45-35-20 tons	6400 mm
SMV 4535 TCX5**	45-37-24 tons	6400 mm
SMV 4537 TC5	45-37-19 tons	6400 mm
SMV 4537 TCX5**	45-41-28 tons	6400 mm

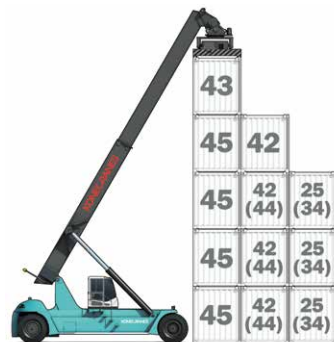

MODEL NAME	CAPACITY	WHEELBASE
SMV 4542 TC5	45-42-24 tons	7250 mm
SMV 4542 TCX5**	45-44-30 tons	7250 mm
SMV 4543 TC5	45-42-25 tons	7500 mm
SMV 4543 TCX5**	45-44-34 tons	7500 mm

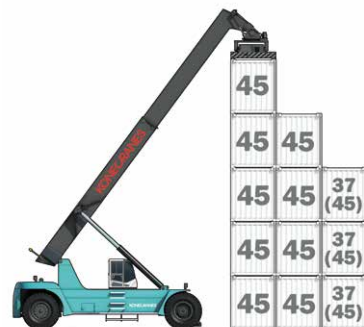

MODEL NAME	CAPACITY	WHEELBASE
SMV 4545 TC5	45-45-37 tons	8000 mm
SMV 4545 TCX5**	45-45-45 tons	8000 mm

Reach stackers for intermodal handling, 41 to 45 tons

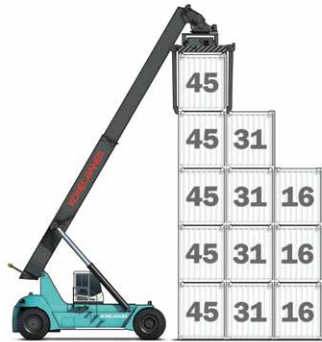

MODEL NAME	CAPACITY	WHEELBASE
SMV 4123 CC5	41-23-9 tons	6400 mm
SMV 4527 CC5	45-27-13 tons	6400 mm
SMV 4531 CC5	45-31-16 tons	6400 mm
SMV 4531 CCX5***	45-33-20 tons	6400 mm
SMV 4533 CC5	45-33-16 tons	6400 mm
SMV 4533 CCX5***	45-37-24 tons	6400 mm

Reach stackers for barge handling, 45 tons

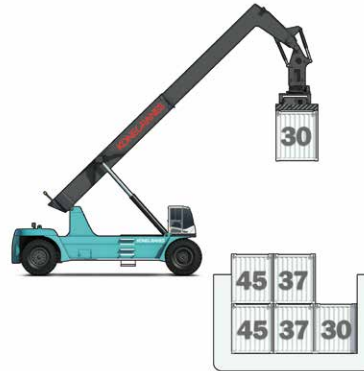

MODEL NAME	CAPACITY	WHEELBASE
SMV 4542 TC4 BH	45-37-23 tons (yard)	7500 mm
	43-30-18 tons (barge)	7500 mm
SMV 4542 TCX4 BH**	45-41-31 tons (yard)	7500 mm
	45-37-26 tons (barge)	7500 mm
SMV 4545 TC3 BH	45-45-35 tons (yard)	9000 mm
	45-37-30 tons (barge)	9000 mm

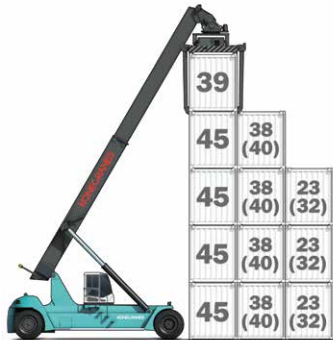

MODEL NAME	CAPACITY	WHEELBASE
SMV 4537 CC5	45-37-22 tons	7250 mm
SMV 4537 CCX5	45-40-28 tons	7250 mm
SMV 4538 CC5	45-38-23 tons	7500 mm
SMV 4538 CCX5***	45-40-32 tons	7500 mm

Reach stackers for industrial handling, 35 to 80 tons



MODEL NAME	CAPACITY	WHEELBASE
SMV 4127	35-50 tons	6400 mm
SMV 4527	35-50 tons	6400 mm
SMV 4531	35-50 tons	6400 mm
SMV 4535	35-50 tons	6400 mm
SMV 4542	40-60 tons	7250 mm
SMV 4545	40-80 tons	8000 mm

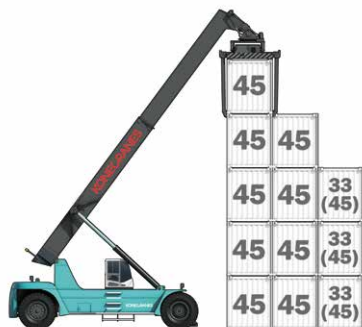

MODEL NAME	CAPACITY	WHEELBASE
SMV 4545 CC5	45-45-33 tons	8000 mm
SMV 4545 CCX5***	45-45-45 tons	8000 mm

*TC5 = 5 high, TC6 = 6 high

**TCX = Capacity with support jacks engaged

***CCX = Capacity with support jacks engaged

Other models upon request

DRIVELINES

Reach stackers 10–25 tons

MODEL		SMV 108–2518				
Engine	Units					
Make		Volvo				
Model		TAD-871-VE				
Emission approval, EU / US		St 4 / Tier 4f				
Power / max speed (ISO 3046)	kW/rpm	185 / 2200				
Torque @ speed (ISO 3046)	Nm/rpm	1160 / 1200				
Displacement / cylinders	L/--	7.7 / 6-cyl				
Alternator power / capacity	W/Amp	2800 / 100				
Fuel consumption (normal)	L/hour	7-13				
Transmission (make / model)		ZF 4WG-191				

MODEL		SMV 108–2518				
Transmission	Units					
Make		ZF				
Model		4WG-191				
Gear shift type		Automatic				
No. of gears (fwd / rev)	No.	4 / 3				
Power rating (max)	kW	200				

Reach stackers 41–45 tons

MODEL		SMV 4127–4545 TCX5 to SMV 4123–4545 CCX5				
Engine	Units					
Make		Volvo	Volvo	Volvo	Scania	Scania
Model		TAD-1171-VE	TAD-1172-VE	TAD-1371-VE	DC-13-087	DC-13-084
Emission approval, EU / US		St 4 / Tier 4f	St 4 / Tier 4f	St 4 / Tier 4f	St 4 / Tier 4f	St 4 / Tier 4f
Power / max speed (ISO 3046)	kW/rpm	265 / 2100	285 / 2000	285 / 1900	257 / 2100	294 / 2100
Torque @ speed (ISO 3046)	Nm/rpm	1785 / 1250	1938 / 1250	1965 / 1200	1950 / 1300	2157 / 1200
Displacement / cylinders	L/--	10.84 / 6-cyl	10.84 / 6-cyl	12.78 / 6-cyl	12.7 / 6-cyl	12.7 / 6-cyl
Alternator power / capacity	W/Amp	3080 / 110	3080 / 110	3080 / 110	2800 / 100	2800 / 100
Fuel consumption (normal)	L/hour	12-18	12-18	14-20	12-18	14-20
Transmission (make / model)		DANA TE27 (opt. ZF 4WG-261)	DANA TE32	DANA TE32	DANA TE27 (opt. ZF 4WG-261)	DANA TE-32

MODEL		SMV 4127–4545 TCX5 to SMV 4123–4545 CCX5				
Transmission	Units					
Make		DANA	ZF	DANA		
Model		TE-27400	4WG-261	TE-32400		
Gear shift type		Automatic	Automatic	Automatic		
No. of gears (fwd / rev)	No.	4 / 4	4 / 3	4 / 4		
Power rating (max)	kW	270	280	325		

DIMENSION MEASUREMENT IDENTIFIERS

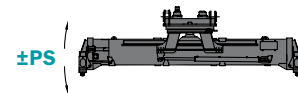
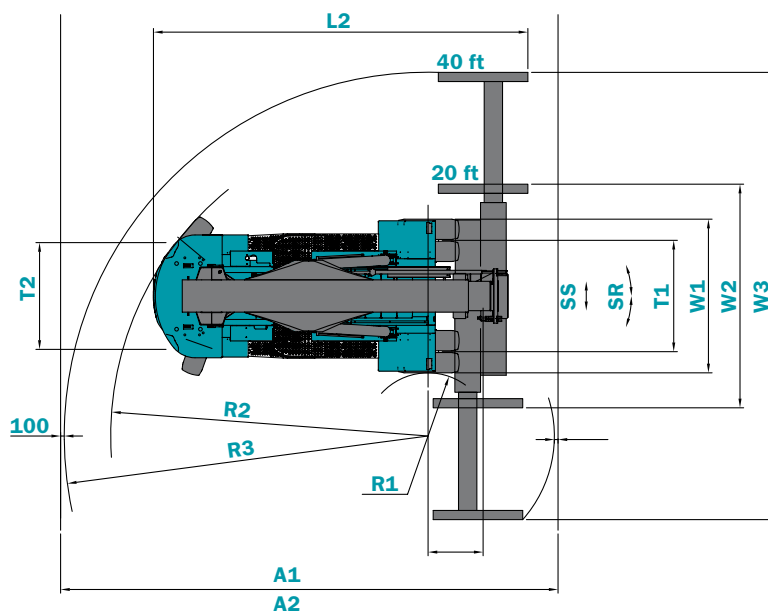
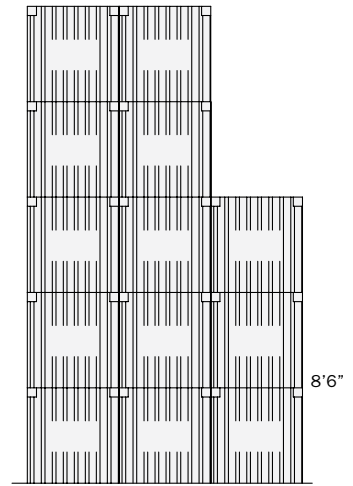
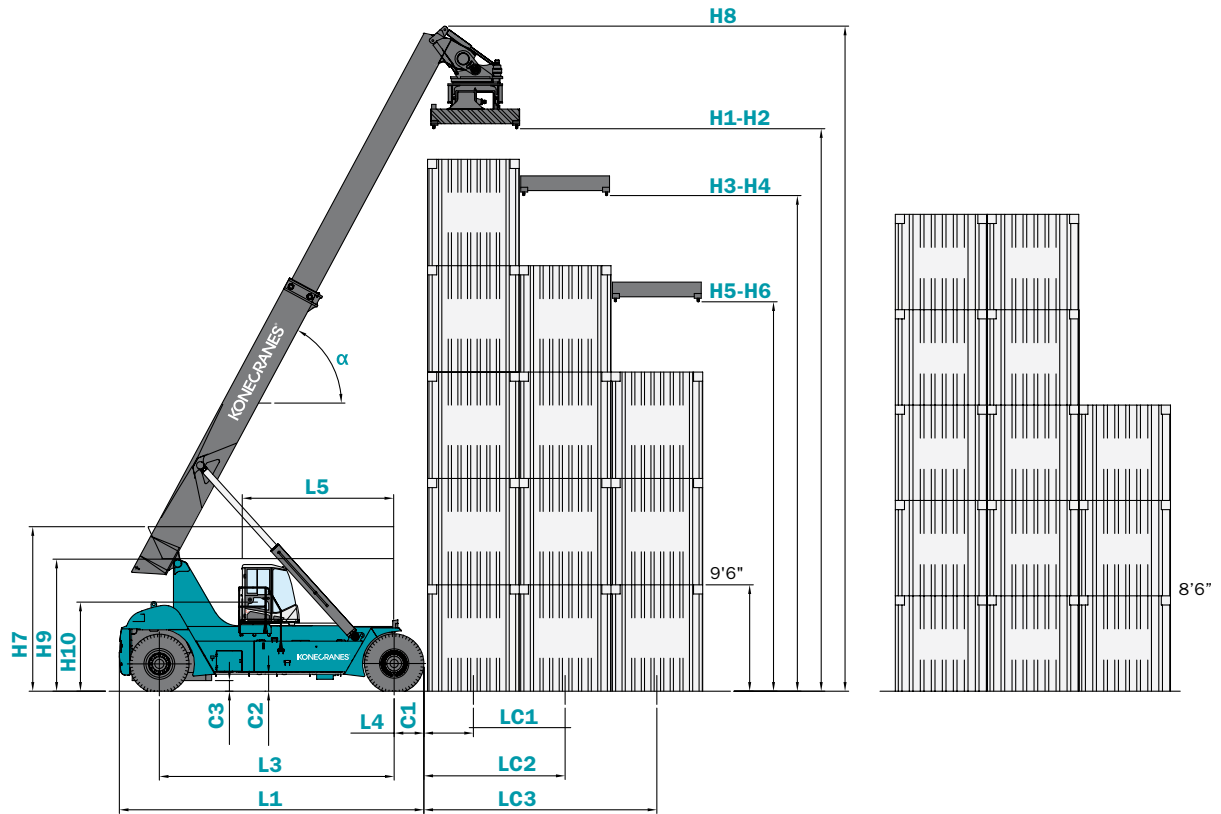

TECHNICAL DATA

Reach stackers for container handling, 10 to 25 tons

MODEL			SMV 108 TC6	SMV 2115 TC3	SMV 2518 TC3	
LIFTING DATA	Dimensions	Identifier	Units			
	Lifting capacity at load center LC1 / LC2 / LC3 (no jacks)		tons	10 / 8 / 5	21 / 15 / 5	25 / 18 / 8
	Lifting capacity at load center LC1 / LC2 / LC3 (with jacks)		tons	-	-	-
	Load centers in row 1 / 2 / 3	LC1 / LC2 / LC3	mm	2700 / 3850 / 6350	1750 / 3850 / 6350	1750 / 3850 / 6350
	Stacking height in row 1 (9'6" / 8'6")			5 x 9'6" / 6 x 8'6"	3 x 9'6" / 3 x 8'6"	3 x 9'6" / 3 x 8'6"
	Spreader type, telescopic, locking			ELME 517 (20-40 ft)	ELME 817 (20-40 ft)	ELME 327 (20 ft)
	Lost load center to face of tires / jacks	L4	mm	700	750	750
Wheelbase	L3	mm	5000	5500	5500	
WEIGHT	Service weight		kg	39500	54600	50000
	Axle pressure front LC1 (unloaded / rated load)		kg	21800 / 38600	29500 / 60100	24500 / 60900
	Axle pressure front LC2 (unloaded / rated load)		kg	23600 / 38900	34600 / 62200	27800 / 60900
	Axle pressure rear LC1 (unloaded / rated load)		kg	17700 / 10900	25100 / 15500	25500 / 14100
	Axle pressure rear LC2 (unloaded / rated load)		kg	15900 / 8600	20000 / 7400	22200 / 7100
WHEELS	Tire type			Pneumatic	Pneumatic	Pneumatic
	Tire dimension / ply rating, front & rear		Inch	14.00 x 24" / PR24	16.00 x 25" / PR32	16.00 x 25" / PR32
	Rim dimensions, front & rear		Inch	10.00 x 24"	11.25 x 25"	11.25 x 25"
	Tire pressure, front / rear		MPa	0.9 / 0.9	0.9 / 0.9	0.9 / 0.9
	Number of wheels, front / rear (X = driven)			4X / 2	4X / 2	4X / 2
	Track width, front / rear	T1 / T2	mm	3286 / 2290	2438 / 2656	2438 / 2656
DIMENSIONS	Boom angle, min - max	α	deg	0 - 66	0 - 47	0 - 47
	Lifting height in twistlocks, min - max at LC1	H1 - H2	mm	1150 - 16200	1200 - 11110	1200 - 11110
	Lifting height in twistlocks, min - max at LC2	H3 - H4	mm	1150 - 13700	1200 - 9000	1200 - 9000
	Lifting height in twistlocks, min - max at LC3	H5 - H6	mm	1150 - 11000	1200 - 7600	1200 - 7600
	Boom height, min - max	H7 - H8	mm	3900 - 18600	4150 - 14300	4150 - 14300
	Truck height over cabin / seat height	H9 - H10	mm	3300 - 2200	3400 - 2250	3400 - 2250
	Sliding cabin stroke (manual / hydraulic)	L5	mm	1800 / 1800	1800 / 1800	1800 / 1800
	Overall length, with - without spreader	L1 - L2	mm	10600 - 6650	10300 - 7300	10300 - 7300
	Drive axle width	W1	mm	4100	3420	3420
	Spreader width, min - max	W2 - W3	mm	6050 - 12175	6050 - 12175	6050
	Spreader sideshift	SS	mm	± 800	± 800	± 800
	Spreader rotation	SR	deg	-105 / 195	-105 / 195	-105 / 195
	Mechanical Pile Slope (side tilt / no power)	PS	deg	± 2	± 2	± 2
	Ground clearance, front / mid / steering axle	C1 / C2 / C3	mm	300 / 450 / 220	300 / 375 / 200	300 / 375 / 200
Aisle width (with 20 ft / 40 ft container)	A1 / A2	mm	10500 / 14000	10400 / 13300	10400	
Turning radius, inner	R1	mm	100	1400	1400	
Turning radius, outer 20 ft / outer 40 ft	R2 / R3	mm	6500 / 8400	7550 / 9200	7550	
PERFORMANCE	Drive speed forward, unloaded / at rated load		km/h	30 / 30	24 / 22	24 / 22
	Drive speed reverse, unloaded / at rated load		km/h	30 / 30	24 / 22	24 / 22
	Lifting speed, unloaded / at 40% load / at rated load		m/s	0.55 / 0.53 / 0.40	0.40 / 0.38 / 0.24	0.40 / 0.38 / 0.24
	Lowering speed, unloaded / at rated load		m/s	0.45 / 0.45	0.45 / 0.45	0.45 / 0.45
	Gradeability, at rated load, 0/2 km/h		% / %	29 / 23	31 / 21	31 / 21
	Towing power, at rated load, 0/2 km/h		kN / kN	144 / 118	190 / 147	190 / 147
DRIVELINE	Engine power (min - max)	EU4	kW	185	185	185
	Engine torque (min - max)	EU4	Nm	1160	1160	1160
	Transmission, gears forward + reverse			ZF 4+3	ZF 4+3	ZF 4+3
	Transmission type, function, shifting			Automatic transmission, torque converter, reverse protection, powershift		
	Drive axle model			Kessler D81	Kessler D91	
	Driving brake system, type			Oil-cooled multiple wet disc brakes (WDB)		
	Parking brake system, type			Dry single disc / spring release		
Steering system / steering axle type			Hydraulic power steer / HD axle + double-acting cylinder			
OTHERS	Load-sensing hydraulics / power-on-demand			Yes / yes	Yes / yes	Yes / yes
	Safety, Monitoring & Overload System			Yes	Yes	Yes
	Hydraulic oil pressure, boom / spreader		MPa	23 / 14	24 / 15	24 / 15
	Diesel / hydraulic tank volumes		Lit	430 / 600	430 / 600	430 / 600
	Noise level inside cab (LM) DIN 45635	EU4	dB(A)	68 / 66	68 / 66	68 / 66
	Noise level inside cab (LpAZ) EN 12053		dB(A)	75	75	75
Noise level outside (LWA) 2000/14/EC		dB(A)	110	110	110	

NOTE 1. TC models do not have support jacks

NOTE 2. Other lifting attachment combinations possible, check factory information

NOTE 3. Four lifting eyes on spreader are standard; extra ones can be provided plus container guides on one side of spreader

NOTE 4. Optional for laden handlers: Hydraulic Pile Slope ±6 deg and Powered Dampening Cylinders ±5 deg + tilt lock

NOTE 5. For available driveline combinations, see driveline chart and latest factory information

Reach stackers for intermodal handling, 41 to 45 tons

SMV 4127 TC5	SMV 4527 TC5	SMV 4527 TC6	SMV 4531 TC5	SMV 4531 TC6	SMV 4535 TC5 (TCX5)	SMV 4537 TC5 (TCX5)
41 / 27 / 14	45 / 27 / 14	45 / 27 / 14	45 / 31 / 16	45 / 31 / 16	45 / 35 / 20	45 / 37 / 19
-	-	-	-	-	45 / 37 / 24	45 / 41 / 28
2000 / 3850 / 6350	2000 / 3850 / 6350	2200 / 3850 / 6350	2000 / 3850 / 6350	2200 / 3850 / 6350	1900 / 3850 / 6350	2000 / 3850 / 6350
5 x 9'6" / 5 x 8'6"	5 x 9'6" / 5 x 8'6"	5 x 9'6" / 6 x 8'6"	5 x 9'6" / 5 x 8'6"	5 x 9'6" / 6 x 8'6"	5 x 9'6" / 5 x 8'6"	5 x 9'6" / 5 x 8'6"
Toplift with 4 x twistlocks, extension 20-40 ft, 4 lifting eyes, safety locking (ELME 817)						
800	800	800	800	800	930	930
6400	6400	6400	6400	6400	6400	6400
68500	68500	69200	71800	72500	79700	83000
37500 / 96500	37500 / 102200	38200 / 104300	37500 / 102200	38200 / 104300	38700 / 103400	42000 / 106700
42000 / 88600	42000 / 88600	42300 / 88900	42000 / 95500	42300 / 95800	43400 / 104400	46500 / 110100
31000 / 13000	31000 / 11300	31000 / 9900	34300 / 14600	34300 / 13200	41000 / 21300	41000 / 21300
26500 / 6900	26500 / 6900	26900 / 7300	29800 / 7300	30200 / 7700	36300 / 10300	36500 / 9900
Pneumatic	Pneumatic	Pneumatic	Pneumatic	Pneumatic	Pneumatic	Pneumatic
18.00 x 25" / PR40	18.00 x 25" / PR40	18.00 x 25" / PR40	18.00 x 25" / PR40	18.00 x 25" / PR40	18.00 x 33" / PR36	18.00 x 33" / PR36
13.00 x 25"	13.00 x 25"	13.00 x 25"	13.00 x 25"	13.00 x 25"	13.00 x 33"	13.00 x 33"
1.0 / 1.0	1.0 / 1.0	1.0 / 1.0	1.0 / 1.0	1.0 / 1.0	1.0 / 1.0	1.0 / 1.0
4X / 2	4X / 2	4X / 2	4X / 2	4X / 2	4X / 2	4X / 2
3030 / 2911	3030 / 2911	3030 / 2911	3030 / 2911	3030 / 2911	3030 / 2911	3030 / 2911
0 - 62	0 - 62	0 - 62	0 - 62	0 - 62	0 - 62	0 - 62
1150 - 15300	1150 - 15300	1150 - 15300	1150 - 15300	1150 - 16300	1300 - 15400	1300 - 15400
1150 - 13400	1150 - 13400	1150 - 13400	1150 - 13400	1150 - 14200	1300 - 13500	1300 - 13500
1150 - 10500	1150 - 10500	1150 - 10500	1150 - 10500	1150 - 11500	1300 - 10500	1300 - 10600
4500 - 18200	4500 - 18200	4500 - 18200	4500 - 18200	4500 - 19300	4675 - 18350	4775 - 18400
3650 - 2450	3650 - 2450	3650 - 2450	3650 - 2450	3650 - 2450	3800 - 2650	3800 - 2650
1800 / 2900	1800 / 2900	1800 / 2900	1800 / 2900	1800 / 2900	1800 / 2900	1800 / 2900
11500 - 8300	11500 - 8300	11700 - 8300	11500 - 8300	11700 - 8300	11500 - 8450	11500 - 8450
4160	4160	4160	4160	4160	4160	4160
6050 - 12175	6050 - 12175	6050 - 12175	6050 - 12175	6050 - 12175	6050 - 12175	6050 - 12175
± 800	± 800	± 800	± 800	± 200	± 800	± 800
-105 / 195	-105 / 195	-105 / 195	-105 / 195	± 200	-105 / 195	-105 / 195
± 2	± 2	± 2	± 2	± 5	± 2	± 2
300 / 465 / 275	300 / 465 / 275	300 / 465 / 275	300 / 465 / 275	300 / 465 / 275	300 / 425 / 450	300 / 425 / 450
11500 / 13600	11500 / 13600	11800 / 13900	11500 / 13600	11800 / 13900	11500 / 13600	11500 / 13600
1500	1500	1500	1500	1500	1500	1500
8550 / 9850	8550 / 9850	8550 / 9900	8550 / 9850	8550 / 9900	8550 / 9850	8550 / 9850
25 / 22	25 / 22	25 / 22	24,5 / 22	24,5 / 22	26 / 23	25 / 22,5
25 / 22	25 / 22	25 / 22	24,5 / 22	24,5 / 22	26 / 23	25 / 22,5
0,38 / 0,35 / 0,23	0,38 / 0,35 / 0,23	0,38 / 0,35 / 0,23	0,38 / 0,35 / 0,23	0,38 / 0,35 / 0,23	0,38 / 0,35 / 0,23	0,38 / 0,35 / 0,23
0,35 / 0,40	0,35 / 0,40	0,35 / 0,40	0,35 / 0,40	0,35 / 0,40	0,35 / 0,40	0,35 / 0,40
29 / 22	29 / 22	25 / 20	25 / 20	25 / 20	24 / 18	24 / 18
315 / 251	315 / 251	300 / 246	300 / 246	300 / 246	260 / 214	260 / 214
256 - 294	256 - 294	256 - 294	256 - 294	256 - 294	256 - 294	256 - 294
1640 - 2172	1640 - 2172	1640 - 2172	1640 - 2172	1640 - 2172	1640 - 2172	1640 - 2172
DANA 4 + 4 / ZF 4 + 3	DANA 4 + 4 / ZF 4 + 3	DANA 4 + 4 / ZF 4 + 3	DANA 4 + 4 / ZF 4 + 3	DANA 4 + 4 / ZF 4 + 3	DANA 4 + 4 / ZF 4 + 3	DANA 4 + 4 / ZF 4 + 3
Automatic transmission, torque converter, reverse protection, powershift						
Kessler D102						
Oil-cooled multiple wet disc brakes (WDB)						
Dry single disc / spring release						
Hydraulic power steer / HD axle + double-acting cylinder						
Yes / yes	Yes / yes	Yes / yes	Yes / yes	Yes / yes	Yes / yes	Yes / yes
Yes	Yes	Yes	Yes	Yes	Yes	Yes
24 / 15	24 / 15	24 / 15	24 / 15	24 / 15	24 / 15	24 / 15
650 / 850	650 / 850	650 / 850	650 / 850	650 / 850	650 / 850	650 / 850
68 / 66	68 / 66	68 / 66	68 / 66	68 / 66	68 / 66	68 / 66
75	75	75	75	75	75	75
111	111	111	111	111	111	111

NOTE 1. TC models do not have support jacks / TCX models have support jacks for increased capacity and lower ground pressure

NOTE 2. Other lifting attachment combinations possible, check factory information

NOTE 3. Four lifting eyes on spreader are standard; extra ones can be provided plus container guides on one side of spreader

NOTE 4. Optional for laden handlers: Hydraulic Pile Slope ±6 deg and Powered Dampening Cylinders ±5 deg + tilt lock

NOTE 5. For available driveline combinations, see driveline chart and latest factory information

NOTE 6. BH = reach stacker for barge handling (other models available)

TECHNICAL DATA

Reach stackers for container handling, 41 to 45 tons

MODEL			SMV 4542 TC5 (TCX5)	SMV 4543 TC5 (TCX5)	SMV 4545 TC5 (TCX5)	SMV 4545 TC3 (BH)	
LIFTING DATA	Dimensions	Identifier	Units				
	Lifting capacity at load center LC1 / LC2 / LC3 (no jacks)		tons	45 / 42 / 24	45 / 42 / 25	45 / 45 / 37	45 / 45 / 35
	Lifting capacity at load center LC1 / LC2 / LC3 (with jacks)		tons	45 / 44 / 30	45 / 44 / 34	45 / 45 / 45	45 / 45 / 35
	Load centers in row 1 / 2 / 3	LC1 / LC2 / LC3	mm	1800 / 3850 / 6350	1800 / 3850 / 6350	2275 / 3850 / 6350	1975 / 3875 / 6375
	Stacking height in row 1 (9'6" / 8'6")			5 x 9'6" / 5 x 8'6"	5 x 9'6" / 5 x 8'6"	5 x 9'6" / 5 x 8'6"	3 x 9'6" / 3 x 8'6"
	Spreader type, telescopic, locking						
	Lost load center to face of tires / jacks	L4	mm	930	930	1025	1025
Wheelbase	L3	mm	7250	7500	8000	9000	
WEIGHT	Service weight		kg	83500	84500	107000	105200
	Axle pressure front LC1 (unloaded / rated load)		kg	42000 / 104400	42500 / 103700	51000 / 114600	52000 / 118300
	Axle pressure front LC2 (unloaded / rated load)		kg	46400 / 116000	47100 / 116000	54600 / 127200	57300 / 122100
	Axle pressure rear LC1 (unloaded / rated load)		kg	41500 / 24100	42000 / 25800	56000 / 37400	53200 / 31900
	Axle pressure rear LC2 (unloaded / rated load)		kg	37100 / 9500	37400 / 10500	52400 / 24800	47900 / 20100
WHEELS	Tire type			Pneumatic	Pneumatic	Pneumatic	Pneumatic
	Tire dimension / ply rating, front & rear		Inch	18.00 x 33" / PR36	18.00 x 33" / PR36	21.00 x 35" / PR40	21.00 x 35" / PR40
	Rim dimensions, front & rear		Inch	13.00 x 33"	13.00 x 33"	15.00 x 35"	15.00 x 35"
	Tire pressure, front / rear		MPa	1.0 / 1.0	1.0 / 1.0	1.0 / 1.0	1.0 / 1.0
	Number of wheels, front / rear (X = driven)			4X / 2	4X / 2	4X / 2	4X / 2
	Track width, front / rear	T1 / T2	mm	3030 / 2911	3030 / 2911	3227 / 3420	3227 / 3420
DIMENSIONS	Boom angle, min - max	α	deg	0 - 61	0 - 59	0 - 55	0 - 62
	Lifting height in twistlocks, min - max at LC1	H1 - H2	mm	1300 - 15400	1300 - 15400	1300 - 15400	1300 - 15400
	Lifting height in twistlocks, min - max at LC2	H3 - H4	mm	1300 - 13500	1300 - 13500	1300 - 14600	1300 - 13500
	Lifting height in twistlocks, min - max at LC3	H5 - H6	mm	1300 - 10400	1300 - 10400	1300 - 11600	1300 - 10500
	Boom height, min - max	H7 - H8	mm	4775 - 18500	4975 - 18500	5100 - 18800	4675 - 18300
	Truck height over cabin / seat height	H9 - H10	mm	3800 - 2650	3800 - 2650	4050 - 2900	3800 - 2650
	Sliding cabin stroke (manual / hydraulic)	L5	mm	1800 / 2900	1800 / 2900	1800 / 2900	1800 / 2900
	Overall length, with - without spreader	L1 - L2	mm	12300 - 9300	12550 - 9550	14150 - 10600	11500 - 8450
	Drive axle width	W1	mm	4160	4160	4600	4160
	Spreader width, min - max	W2 - W3	mm	6050 - 12175	6050 - 12175	6050 - 12175	6050 - 12175
	Spreader sideshift	SS	mm	± 800	± 800	± 800	± 800
	Spreader rotation	SR	deg	-105 / 195	-105 / 195	-105 / 195	-105 / 195
	Mechanical Pile Slope (side tilt / no power)	PS	deg	± 2	± 2	± 2	± 2
	Ground clearance, front / mid / steering axle	C1 / C2 / C3	mm	300 / 425 / 450	300 / 425 / 450	300 / 300 / 500	300 / 300 / 500
Aisle width (with 20 ft / 40 ft container)	A1 / A2	mm	12650 / 13850	12900 / 14000	15200 / 15400	15900 / 15900	
Turning radius, inner	R1	mm	2200	2600	2800	3250	
Turning radius, outer 20 ft / outer 40 ft	R2 / R3	mm	9750 / 10400	10100 / 10750	11300 / 11300	12400 / 12400	
PERFORMANCE	Drive speed forward, unloaded / at rated load		km/h	25 / 22,5	25 / 22,5	24 / 20	24 / 20
	Drive speed reverse, unloaded / at rated load		km/h	25 / 22,5	25 / 22,5	24 / 20	24 / 20
	Lifting speed, unloaded / at 40% load / at rated load		m/s	0.38 / 0.35 / 0.23	0.37 / 0.34 / 0.22	0.35 / 0.33 / 0.17	0.35 / 0.33 / 0.17
	Lowering speed, unloaded / at rated load		m/s	0.35 / 0.40	0.35 / 0.40	0.25 / 0.35	0.25 / 0.35
	Gradeability, at rated load, 0/2 km/h		% / %	23 / 17	23 / 17	22 / 16	22 / 16
	Towing power, at rated load, 0/2 km/h		kN / kN	260 / 214	260 / 214	260 / 214	260 / 214
DRIVELINE	Engine power (min - max)	EU4	kW	256 - 294	256 - 294	256 - 294	256 - 294
	Engine torque (min - max)	EU4	Nm	1640 - 2172	1640 - 2172	1640 - 2172	1640 - 2172
	Transmission, gears forward + reverse			DANA 4 + 4 / ZF 4 + 3	DANA 4 + 4 / ZF 4 + 3	DANA 4 + 4 / ZF 4 + 3	DANA 4 + 4 / ZF 4 + 3
	Transmission type, function, shifting						
	Drive axle model			Kessler D106		Kessler D111	Kessler D111
	Driving brake system, type						
	Parking brake system, type						
Steering system / steering axle type							
OTHERS	Load-sensing hydraulics / power-on-demand			Yes / yes	Yes / yes	Yes / yes	Yes / yes
	Safety, Monitoring & Overload System			Yes	Yes	Yes	Yes
	Hydraulic oil pressure, boom / spreader		MPa	25 / 15	25 / 15	24 / 15	24 / 15
	Diesel / hydraulic tank volumes		Lit	650 / 850	650 / 850	700 / 950	700 / 950
	Noise level inside cab (LM) DIN 45635	EU4	dB(A)	68 / 66	68 / 66	68 / 66	68 / 66
Noise level inside cab (LpAZ) EN 12053		dB(A)	75	75	75	75	
Noise level outside (LWA) 2000/14/EC		dB(A)	111	111	111	111	

NOTE 1. CC models do not have support jacks / CCX models have support jacks for increased capacity and lower ground pressure

NOTE 2. Other lifting attachment combinations possible, check factory information

NOTE 3. Four lifting eyes on spreader are standard; extra ones can be provided plus container guides on one side of spreader

NOTE 4. Standard for intermodal handlers: Hydraulic Pile Slope ±6 deg and Powered Dampening Cylinders ±5 deg + tilt lock

NOTE 5. For available driveline combinations, see driveline chart and latest factory information

SMV 4123 CC5	SMV 4527 CC5	SMV 4531 CC5 (CCX5)	SMV 4533 CC5 (CCX5)	SMV 4537 CC5 (CCX5)	SMV 4538 CC5 (CCX5)	SMV 4545 CC5 (CCX5)
41 / 23 / 9	45 / 27 / 13	45 / 31 / 16	45 / 33 / 16	45 / 37 / 22	45 / 38 / 23	45 / 45 / 33
-	-	45 / 33 / 20	45 / 37 / 24	45 / 40 / 28	45 / 40 / 32	45 / 45 / 45
2000 / 3850 / 6350	1900 / 3850 / 6350	1900 / 3850 / 6350	2000 / 3850 / 6350	1800 / 3850 / 6350	1800 / 3850 / 6350	2275 / 3850 / 6350
5 x 9'6" / 5 x 8'6"	5 x 9'6" / 5 x 8'6"	5 x 9'6" / 6 x 8'6"	5 x 9'6" / 5 x 8'6"	5 x 9'6" / 5 x 8'6"	5 x 9'6" / 5 x 8'6"	5 x 9'6" / 5 x 8'6"
Toplift 4 x twistlocks, trailer lift 4 x lifting legs, extension 20/B7/30/40 ft, 4 lifting eyes, safety locking (ELME 857)						
800	930	930	930	930	930	1025
6400	6400	6400	6400	7250	7500	8000
72500	77600	82200	87200	89500	90000	110000
43000 / 101900	44200 / 108900	44200 / 108900	48000 / 112700	48000 / 110400	48000 / 109200	54000 / 117600
48700 / 88500	50200 / 97500	50200 / 104200	53600 / 110400	53500 / 114800	53700 / 116100	58400 / 131000
29500 / 11600	33400 / 13700	38000 / 18300	39200 / 19500	41500 / 24100	42000 / 25800	56000 / 37400
23800 / 7000	27400 / 7100	32000 / 9000	33600 / 9800	36000 / 11700	36300 / 11900	51600 / 24000
Pneumatic	Pneumatic	Pneumatic	Pneumatic	Pneumatic	Pneumatic	Pneumatic
18.00 x 25" / PR40	18.00 x 33" / PR36	18.00 x 33" / PR36	18.00 x 33" / PR36	18.00 x 33" / PR36	18.00 x 33" / PR36	21.00 x 35" / PR40
13.00 x 25"	13.00 x 33"	13.00 x 33"	13.00 x 33"	13.00 x 33"	13.00 x 33"	15.00 x 35"
1.0 / 1.0	1.0 / 1.0	1.0 / 1.0	1.0 / 1.0	1.0 / 1.0	1.0 / 1.0	1.0 / 1.0
4X / 2	4X / 2	4X / 2	4X / 2	4X / 2	4X / 2	4X / 2
3030 / 2911	3030 / 2911	3030 / 2911	3030 / 2911	3030 / 2911	3030 / 2911	3227 / 3420
0 - 62	0 - 62	0 - 62	0 - 62	0 - 61	0 - 59	0 - 55
650 - 14800	800 - 14900	800 - 14900	800 - 14900	800 - 14900	800 - 14900	1300 - 15000
650 - 13000	800 - 13000	800 - 13000	800 - 13000	800 - 13000	800 - 13000	1300 - 14100
650 - 10100	800 - 10000	800 - 10000	800 - 10000	800 - 9900	800 - 9900	1300 - 11100
4500 - 18200	4675 - 18350	4675 - 18350	4775 - 18400	4775 - 18500	4975 - 18500	5100 - 18800
3650 - 2450	3800 - 2650	3800 - 2650	3800 - 2650	3800 - 2650	3800 - 2650	4050 - 2900
2900	2900	2900	2900	2900	2900	2900
11500 - 8300	11550 - 8450	11550 - 8450	11550 - 8450	12300 - 9300	12550 - 9550	14150 - 10600
4160	4160	4160	4160	4160	4160	4600
6050 - 12175	6050 - 12175	6050 - 12175	6050 - 12175	6050 - 12175	6050 - 12175	6050 - 12175
± 800	± 800	± 800	± 800	± 800	± 800	± 800
-105 / 195	-105 / 195	-105 / 195	-105 / 195	-105 / 195	-105 / 195	-105 / 195
± 6	± 6	± 6	± 6	± 6	± 6	± 6
300 / 465 / 275	300 / 465 / 450	300 / 465 / 450	300 / 425 / 450	300 / 425 / 450	300 / 425 / 450	300 / 300 / 500
11500 / 13600	11500 / 13600	11500 / 13600	11500 / 13600	12650 / 13850	12900 / 14000	15200 / 15400
1500	1500	1500	1500	2200	2200	2800
8550 / 9850	8550 / 9850	8550 / 9850	8550 / 9850	9750 / 10400	10100 / 10750	11300 / 11300
24.5 / 22	26 / 23	26 / 23	25 / 22.5	24.5 / 22	24.5 / 22	25 / 20
24.5 / 22	26 / 23	26 / 23	25 / 22.5	24.5 / 22	24.5 / 22	25 / 20
0.38 / 0.35 / 0.23	0.38 / 0.35 / 0.23	0.38 / 0.35 / 0.23	0.38 / 0.35 / 0.23	0.38 / 0.35 / 0.23	0.38 / 0.35 / 0.23	0.35 / 0.33 / 0.17
0.35 / 0.40	0.35 / 0.40	0.35 / 0.40	0.35 / 0.40	0.35 / 0.40	0.35 / 0.40	0.25 / 0.35
25 / 20	24 / 18	24 / 18	24 / 18	23 / 17	23 / 17	22 / 16
300 / 246	260 / 214	260 / 214	260 / 214	260 / 214	260 / 214	260 / 214
256 - 294	256 - 294	256 - 294	256 - 294	256 - 294	256 - 294	256 - 294
1640 - 2172	1640 - 2172	1640 - 2172	1640 - 2172	1640 - 2172	1640 - 2172	1640 - 2172
DANA 4 + 4 / ZF 4 + 3	DANA 4 + 4 / ZF 4 + 3	DANA 4 + 4 / ZF 4 + 3	DANA 4 + 4 / ZF 4 + 3	DANA 4 + 4 / ZF 4 + 3	DANA 4 + 4 / ZF 4 + 3	DANA 4 + 4 / ZF 4 + 3
Fully automatic transmission, torque converter, reverse protection, powershift						
Kessler D102				Kessler D106		Kessler D111
Oil-cooled multiple wet disc brakes (WDB)						
Dry single disc / spring release						
Hydraulic power steer / HD axle + double-acting cylinder						
Yes / yes	Yes / yes	Yes / yes	Yes / yes	Yes / yes	Yes / yes	Yes / yes
Yes	Yes	Yes	Yes	Yes	Yes	Yes
24 / 15	24 / 15	24 / 15	24 / 15	25 / 15	25 / 15	24 / 15
650 / 850	650 / 850	650 / 850	650 / 850	650 / 850	650 / 850	700 / 950
68 / 66	68 / 66	68 / 66	68 / 66	68 / 66	68 / 66	68 / 66
75	75	75	75	75	75	75
111	111	111	111	111	111	111

This publication is for general informational purposes only. Konecranes reserves the right at any time, without notice, to alter or discontinue the products and/or specifications referenced herein. This publication creates no warranty on the part of Konecranes, express or implied, including but not limited to any implied warranty or merchantability or fitness for a particular purpose.



INDUSTRIAL
CRANES



NUCLEAR
CRANES



PORT
CRANES



HEAVY-DUTY
LIFT TRUCKS



SERVICE



MACHINE
TOOL
SERVICE

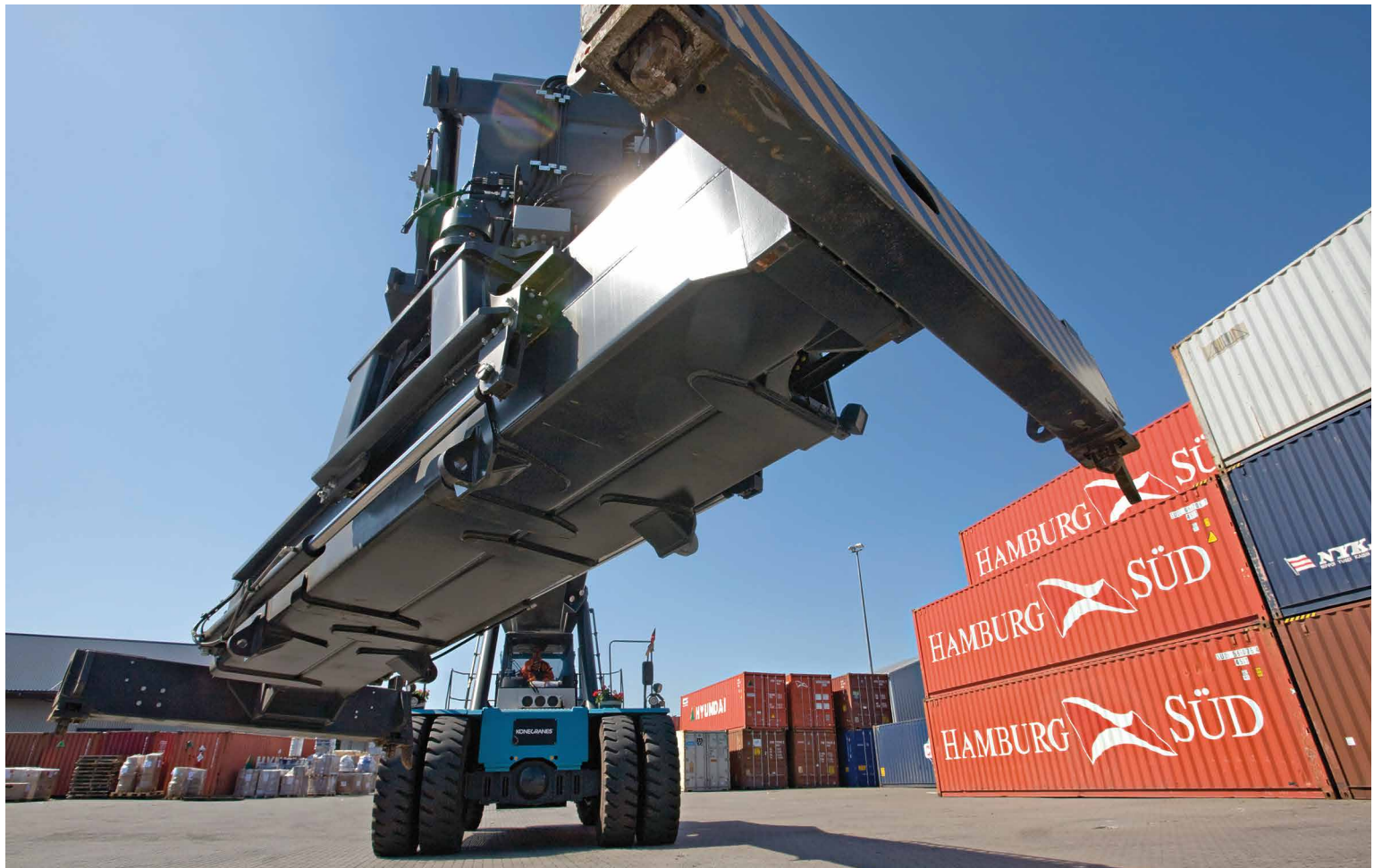

FORKLIFTCENTER BV
Hornweg 18 /1045AR /Amsterdam
www.forkliftcenter.com / info@forkliftcenter.com
Tel +31-20-4974101