

# PANORAMIC P 32.6L / PLUS

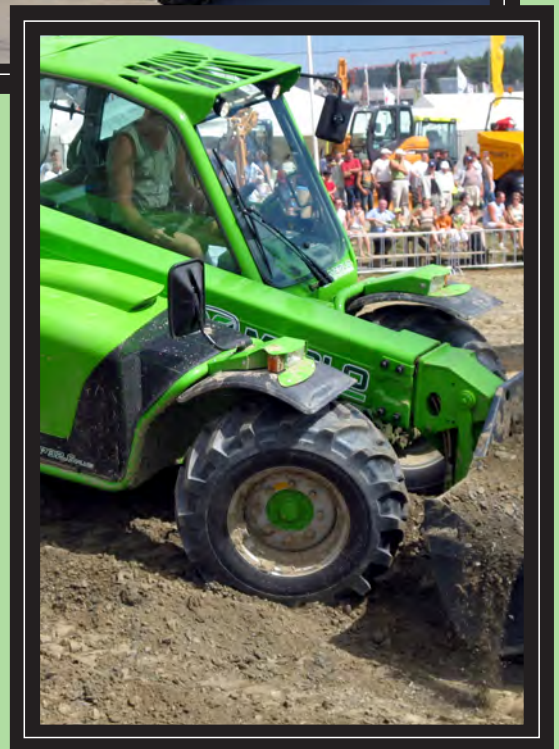
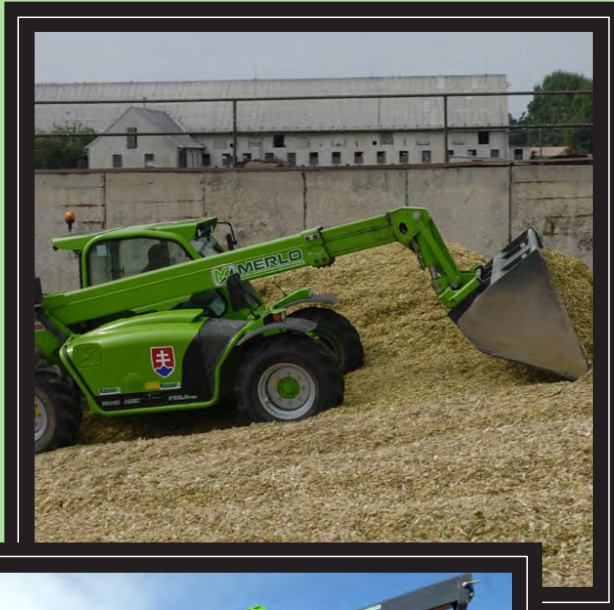

**MERLO**  
AUSTRALIA

## KEY SPECIFICATIONS

Total weight unladen with forks (kg)	5960
Maximum load capacity (kg)	3000
Maximum lift height (m)	6.4
Maximum forward reach (m)	3.5
Lift height at maximum capacity (m)	4.2
Forward reach at maximum load capacity (m)	1.3
Load capacity at maximum height (kg)	1100
Load capacity at maximum forward reach (kg)	1100
Engine (make/number of cylinders)	Deutz/4
Tier 3 engine power (kW/hp)	74.9/102
Fuel capacity (l)	100
Maximum speed (kph)	25/40(plus)
Hydraulic gear pump (bar-l/min)	210/100
Hydraulic oil capacity (l)	85
Electrical circuit (V)	12
Battery (Ah)	100
Cab compliant with ROPS/FOPS standards	✓
4x1 Electro Mechanical joystick controls	✓
Tac-Lock hydraulic attachment coupling	✓
Auxiliary boom hydraulics	✓
Two standard forks (1200mm)	✓
Hydrostatic transmission	✓
Finger touch direction control	✓
Inching pedal for precise control	✓
Permanent 4 wheel drive	✓
Four wheel steering	✓
Dry type disc brakes on all wheels	✓
Automatically locking parking brake	✓
405/70-20 tyres	✓
Rear differential lock	✓
Four cab working lights (2f & 2r)	✓
12V electrical on boom head	✓
Air suspension seat	✓
Front window protection	✓
Full size cab with air conditioning	✓
Load Management System	✓

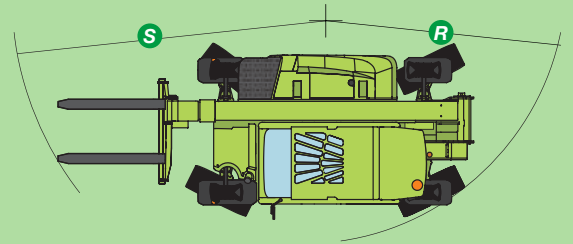
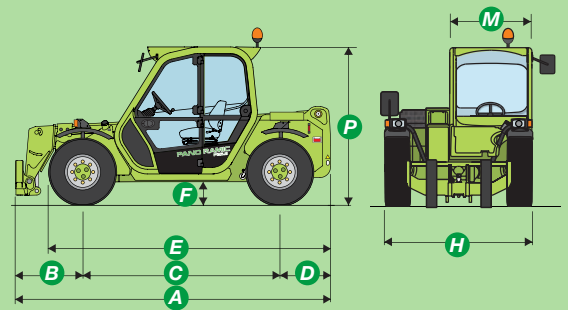

## DIMENSIONS

A (mm)	4220
B (mm)	970
C (mm)	2720
D (mm)	530
E (mm)	3780
F (mm)	385
H (mm)	2000
M (mm)	995
P (mm)	2150/2000(L)
R (mm)	3700
S (mm)	4550

## P32.6 Load Chart - Standard forks

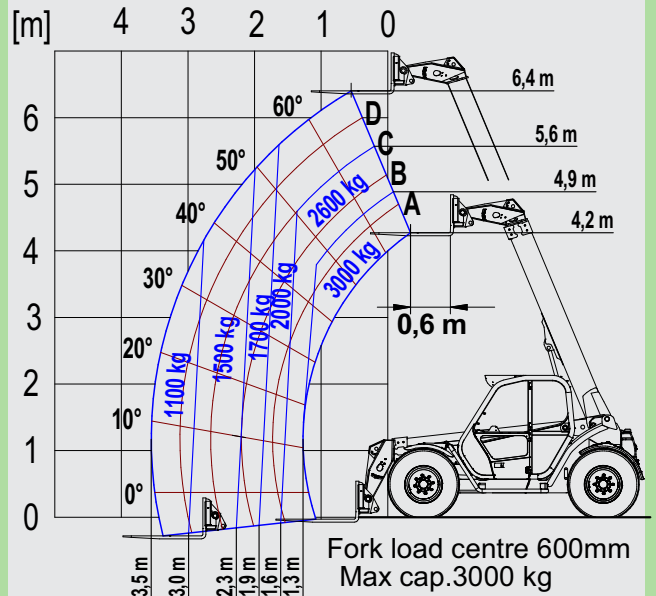

**1300 657325**  
merloaustralia.com.au