

CAPABILITY STATEMENT





HUNTER PLANT HIRE THANKS YOU FOR THE OPPORTUNITY TO PRESENT OUR CAPABILITY STATEMENT.

AS SPECIALISTS IN LARGE CAPACITY FORKLIFTS AND THE ONLY OEM MANUFACTURER OF UNDERGROUND SKID STEER LOADERS IN AUSTRALIA, WE DELIVER CUSTOMISED SOLUTIONS THAT KEEP YOUR OPERATIONS MOVING.



ABOUT US

Hunter Plant Hire is a specialist plant and equipment hire business with over two decades of industry experience. Founded in August 2004, we have built our reputation as the go to partner for complex lifting and underground works across Australia.

Based in Thornton, NSW, we supply plant and equipment Australia-wide with rapid deployment across mining, freight and logistics, major civil construction and heavy industry

We're the only company in Australia that manufactures underground skid steer loaders approved for mine use, and we operate one of the most extensive fleets of large capacity forklifts. When standard equipment won't do the job, we engineer the solution.

Hunter Plant Hire is recognised for responsive service, innovative problem solving, and our commitment to understanding what our customers actually need to get the job done.

OUR TEAM

The team brings together specialist skills in project management, cost planning, construction delivery, Hunter Plant Hire is led by Operations Manager, Brock McPhee and Service Manager, Ryan McPhee. Our team combines technical expertise with practical experience, ensuring every project receives the attention and innovation it deserves.

We work closely with our customers from initial consultation through to project completion, taking ownership of outcomes and maintaining the responsive, solution-focused approach that has become our signature.



Brock McPhee

Operations Manager

brock@hunterplanthire.com.au



Ryan McPhee

Service Manager

ryan@hunterplanthire.com.au

SERVICES

Hunter Plant Hire provides specialised equipment hire and manufacturing services to mining, freight and logistics, major civil construction, and heavy industry sectors across Australia.

DRY HIRE EQUIPMENT

- Large capacity forklifts
- Telehandlers for construction and industrial applications
- Reach stackers for port and freight operations
- Underground skid steer loaders for mining operations

EQUIPMENT SERVICING

- Comprehensive servicing of existing customer's owned equipment
- Maintenance support for existing customers
- Technical support and parts supply

UNDERGROUND SKID STEER MANUFACTURING

- Purpose built underground skid steer loaders
- Approved for use in underground mines
- Custom modifications to meet site specific requirements
- Full compliance with mine design specifications

CUSTOM ENGINEERING SOLUTIONS

- Specialised carriage design and manufacturing
- Equipment modifications for specific applications
- Engineering solutions when standard equipment won't work
- Fleet expansion to meet unique customer requirements

Every service is delivered with our commitment to understanding your specific needs and providing solutions that work, not just equipment that fits.

VALUES

INTEGRITY

Transparent, honest dealings in all circumstances

INNOVATION

Continuous improvement and creative problem solving

RELIABILITY

Consistent delivery and availability when challenges arise

KEY STRENGTHS

ENGINEERING EXCELLENCE

We don't just hire equipment, we engineer solutions. As the only Australian manufacturer of underground skid steer loaders, we design and build equipment that doesn't exist elsewhere. Whether it's custom forklift carriages for handling steel coils or modifying underground loaders for specific mine requirements, we combine manufacturing expertise with practical innovation. If standard equipment won't do the job, we'll engineer what will.

RESPONSIVENESS

When your equipment breaks down at 2am, we answer the phone. For customers operating around the clock - particularly ports, mines, and continuous manufacturing - we provide genuine 24/7 support that keeps your operations moving. Fast quotes, rapid parts supply, emergency callouts, and immediate problem solving are standard practice, not premium services.

COLLABORATIVE SOLUTIONS

We sell solutions, not products. Before recommending equipment, we take time to understand what you're trying to achieve - your task, constraints, and operational goals. We match the right equipment to your specific needs, and if we don't have it, we'll engineer it or expand our fleet to meet your requirements. Your success drives our approach.

OUR APPROACH

OUR PROJECT APPROACH ENSURES YOU GET THE RIGHT SOLUTION, DELIVERED EFFICIENTLY.

1.

UNDERSTAND YOUR TASK

We talk to you about what you're trying to achieve, not just what equipment you think you need. Detailed discussions help us understand your constraints and requirements.

2.

MATCH EQUIPMENT TO TASK

Using our specialist knowledge, we identify the best equipment for your specific application, considering efficiency, safety, and cost effectiveness.

3.

ENGINEER SOLUTIONS

If standard equipment won't work, we look to engineer a solution. This might involve custom modifications, specialised attachments, or completely new builds.

4.

EXPAND CAPABILITIES

When we can't engineer a solution with existing equipment, and it makes business sense, we expand our fleet to meet your requirements, ensuring you get the right tool for the job.

FEATURED PROJECT



FEATURED PROJECT



UNDERGROUND MINE LOADER – COMET, QLD

Client: **Ensham Coal Mine**
 Project: **Customised new build underground loader**

We took our standard underground mine loader and modified it to meet Ensham’s site specific requirements while maintaining full compliance with approved mine design specifications. The project required detailed engineering to balance operational needs with strict safety and regulatory requirements.

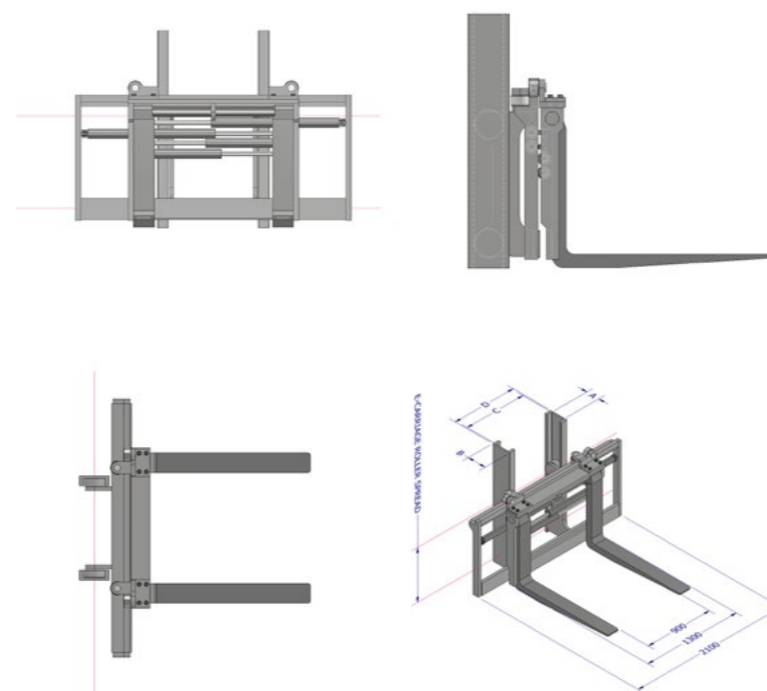

CUSTOM FORKLIFT CARRIAGE - PORT KEMBLA, NSW

Client: **Toll Group**
 Project: **Specialised steel coil handling solution**

Toll needed to handle steel coils of various weights and sizes and efficiently pack them into shipping containers. No standard forklift carriage could handle the task effectively. We engineered and manufactured a complete custom carriage solution, enabling Toll to carry out operations efficiently.



TESTIMONIALS

"We are currently hiring Hunter Plant Hire's 60 Tonne Reach Stacker and couldn't be happier with both the machine and the service. From the start, the process has been straight forward and professional.

The equipment arrived to us in excellent condition, is clearly well-maintained, and has been operating reliably day after day. Its performance under consistent, heavy use has given our team confidence to get the job done efficiently and safely."

Scott Vella
General Manager
Phoenix Underground

"Hunter Plant Hire has consistently delivered reliable service and equipment, particularly with their range of top lifter forklifts, 5-tonne, and 16-tonne units. We've relied on their machines for heavy-duty container handling and yard operations for over 15 years. The forklifts are perfectly suited to the demands of intermodal logistics. Their top lifters offer excellent reach and stability, while the 5t and 16t forklifts provide the versatility and strength we need for varied lifting tasks. The team at Hunter Plant Hire is responsive with having local professional technicians available that are always willing to go the extra mile to ensure operations continue. Their reliability and commitment to quality make them a trusted partner in our daily operations."

Darrin Cox
Senior Manager - Intermodal
Toll Global Logistics



FOR MINING, LOGISTICS, CONSTRUCTION, AND HEAVY INDUSTRY OPERATIONS REQUIRING SPECIALISED LIFTING SOLUTIONS, HUNTER PLANT HIRE DELIVERS THE EXPERTISE AND EQUIPMENT YOU NEED.

WE WELCOME THE OPPORTUNITY TO UNDERSTAND YOUR REQUIREMENTS AND DEMONSTRATE HOW OUR SOLUTION FOCUSED APPROACH CAN IMPROVE YOUR OPERATIONAL EFFICIENCY.



CONTACT

Hunter Plant Hire Pty Ltd

27 Pipeclay Avenue

Thornton NSW 2322

Phone: 02 4964 9959

Email: office@hunterplanthire.com.au



facebook.com/HunterPlantHireNSW



linkedin.com/company/hunter-plant-hire-nsw



instagram.com/hunterplanthire_nsw